

# OpenLine™

THE OPEN CHANNEL UV DISINFECTION SYSTEM

*Robust, water tight electrical and pneumatic connections allow for quick and easy servicing of lamp modules.*



*UV Dose, Flow, Intensity and Alarm indications may be continually monitored or adjusted at the NEMA 4X Human Machine Interface Panel.*



*Electronic ballasts can be mounted under the UV channel to reduce the footprint, while providing easy access for service or future expansion.*

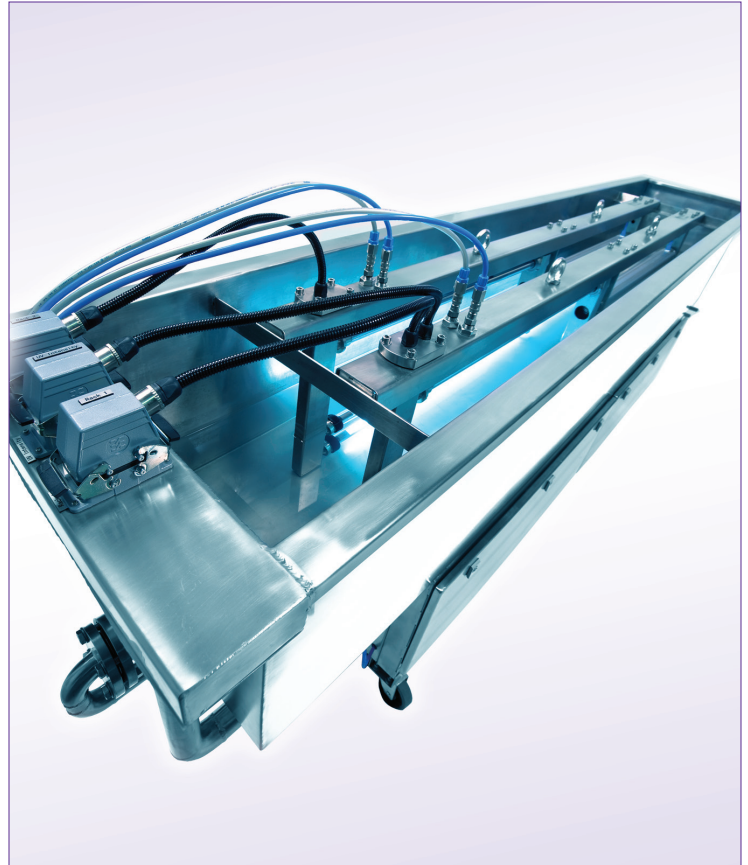

MUNICIPAL WASTEWATER DISINFECTION

## CHEMICAL-FREE DISINFECTION IS HERE!

*The environmental concerns associated with chemical disinfection are numerous and costly to manage. That's why industry professionals are converting to UV disinfection in record numbers.*

The OpenLine UV system from Aquionics is the smart way to convert to chemical-free disinfection. It is engineered for easy installation and operation. Standard flanges make connection to process piping trouble-free. The OpenLine features a stainless steel channel and is available in six standard single-channel sizes.

Water level is accurately maintained with the use of the control weir. Lamps and the quartz lamp-sleeves are immediately accessible, plus pneumatically driven wiping of the quartz sleeves is standard.

Process variables can be quickly monitored and adjusted at the NEMA 4X Human Machine Interface (HMI) panel.

Single channel flows up to 700 gpm are available (higher flows are accommodated through the use of multiple units operated in either series or parallel). Minimal civil work is required as the need for the construction of a concrete channel is eliminated with the OpenLine UV system.

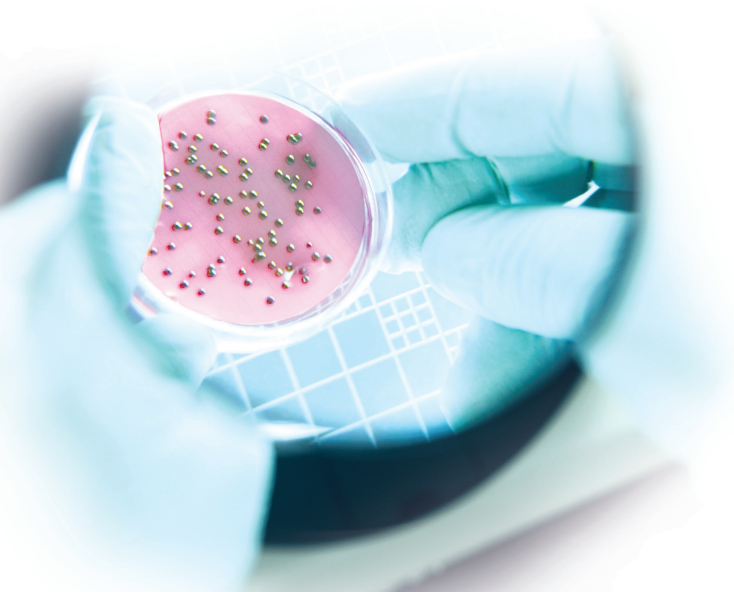

**AQUIONICS**  
UV That Works!

# OpenLine™

THE OPEN CHANNEL UV DISINFECTION SYSTEM

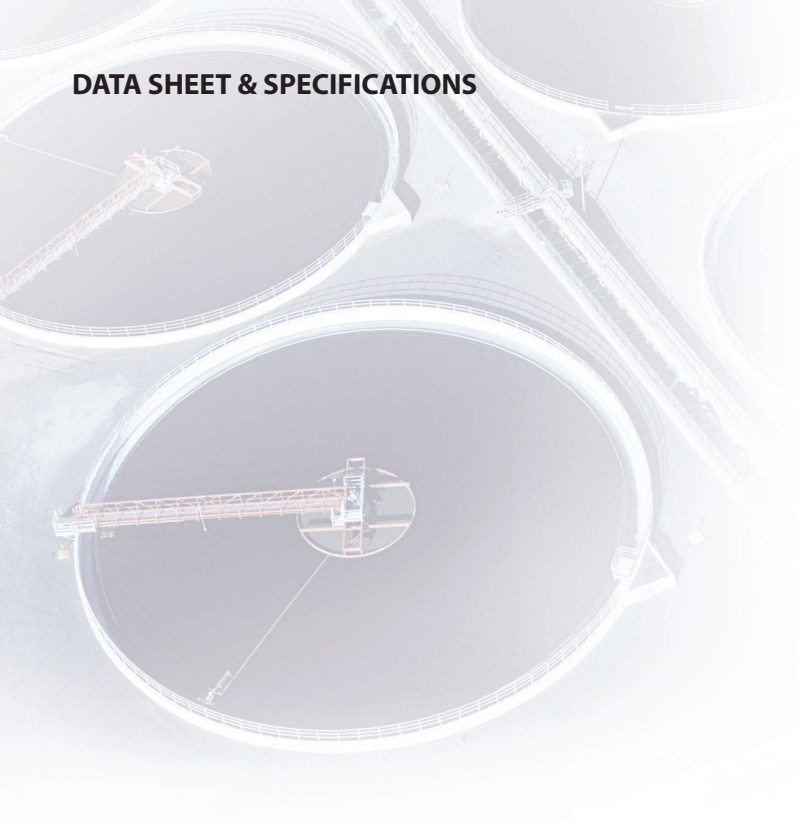

	OpenLine 20	OpenLine 40	OpenLine 60	OpenLine 80	OpenLine 90	OpenLine 120	OpenLine 160
Flow† (gpm)	90	175	265	350	400	525	700
Number of Lamps	2	4	6	8	9	12	16
Lamp Power (kW)	0.48	0.96	1.44	1.92	2.16	2.88	3.84

Power Supply 110/220 Volt, 50/60 Hz  
 UV Dose‡ [mJ/cm²] > 30

†Flow can be increased by positioning two units in series or splitting flow between two units in parallel.

‡ UV Dose dependent on UV-Transmittance, TSS and water temperature. Values quoted assume 65% UV-T, TSS < 20 mg/L and max water temp 90° F.

## The OpenLine System Includes:

- UV Intensity Monitor
- Lamp Hour Counter
- Lamp Status Monitoring
- Failure Alarms
- 14,000 Hour Lamp Life Guarantee
- Standard 18 Month Warranty

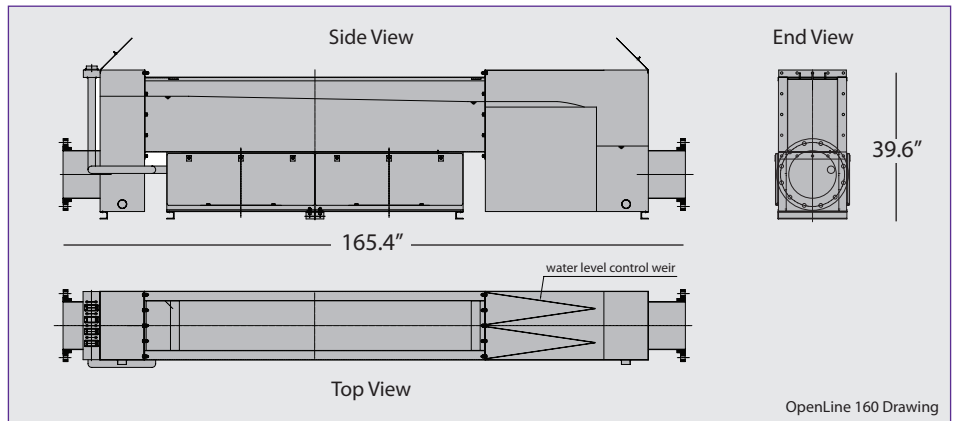

A HALMA COMPANY

Celebrating 80 Years of Pure Performance from the UV Technology Pioneers



1455 Jamike Avenue, Suite 100 | Erlanger, KY 41018 | P 859.341.0710 | T 800.925.0440 | F 859.341.0350 | WWW.AQUIONICS.COM