

KEYSTONE

CONVEYOR CORPORATION

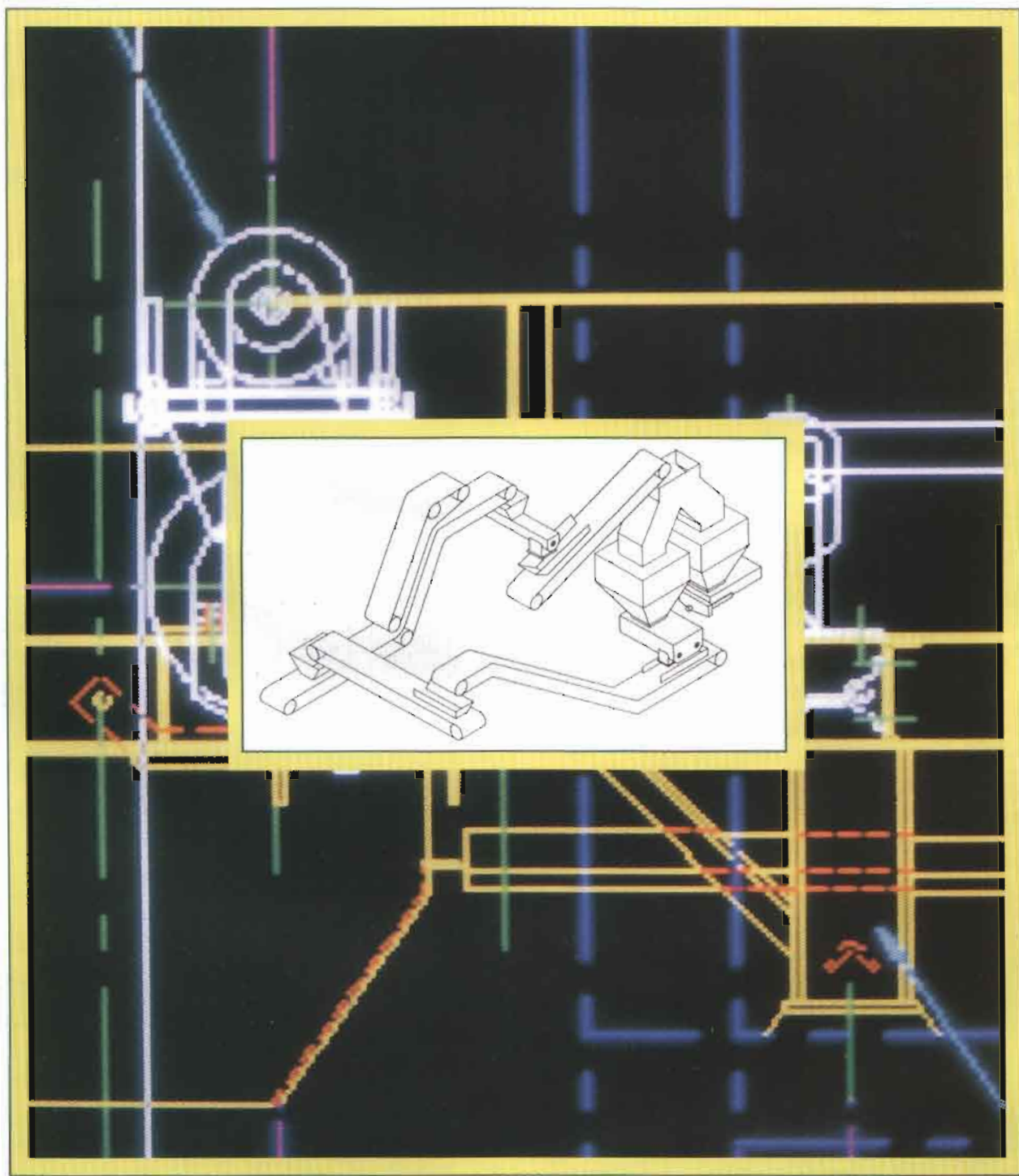

Specialists in Conveyor Systems

19992 Ferret Street NW • Elk River, MN 55330 • Phone 763-712-1322 • Fax 763-712-1324
www.keystoneconveyor.com

Your Conveyor Specialist

KEYSTONE specializes in providing straightforward solutions to help you meet your conveying system needs.

Our specialist have the knowledge and years of “hands-on” experience to offer a reliable, common sense approach to solve your unique conveying application problems.

KEYSTONE will help you from the beginning to the end. Our staff is here to offer:

- ◆ Application Design Work
- ◆ Reference Specifications
- ◆ System Layout Drawings
- ◆ Budget Pricing

KEYSTONE is your resource for the important preliminary tasks in proper systems design. We welcome your inquiries and urge you to take advantage of our application assistance.

When you need the best approach to make your system meet its performance requirements, while staying within those ever present physical and budget constraints, you need only contact KEYSTONE CONVEYOR.





Your Conveyor Manufacturer

KEYSTONE has the expertise to handle your conveyor needs from single conveyors to complete systems, large and small.

Our project managers have the experience and a commitment to work for your best interests. We will:

- ◆ Design using proven CEMA methods
- ◆ Incorporate only reliable, high quality component hardware.
- ◆ Oversee production and quality control of each project.
- ◆ Manufacture and deliver the systems within your time schedule.

KEYSTONE is also aware of our obligation to our customers. We will offer only the best effort possible to react to your needs and deadlines. We understand that today's demanding project requirements and schedules require an absolute commitment to provide nothing less.

Call KEYSTONE CONVEYOR today at 763-712-1322 or fax us at 763-712-1324



KEYSTONE

CONVEYOR CORPORATION

Specialists in Conveyor Systems

Keystone Conveyor has the expertise to design and manufacture any system to meet today's demanding project requirements. Typical systems and features include:

(1) Belt Conveyors

- Side Wall Conveyors
- Troughed Conveyors
- Slider Bed Conveyors
- Shuttle Conveyors
- Pivoting Conveyors
- Stack-Out Conveyors

(2) Screw Conveyors

- Live Bottom Bins
- Metering Bins
- Mixing Screws
- Dewatering Screws
- Leveling Screws
- Shaftless Screws

(3) Gates

- Diverter Gates
- Driplless Gates
- Shut-Off Gates

(4) Elevators

- Belt Elevators
- Bucket Elevators

(5) Equipment

- Belt Accessories
- Blenders
- Dust Collection
- Storage Bins & Silos
- Bag Feed Systems

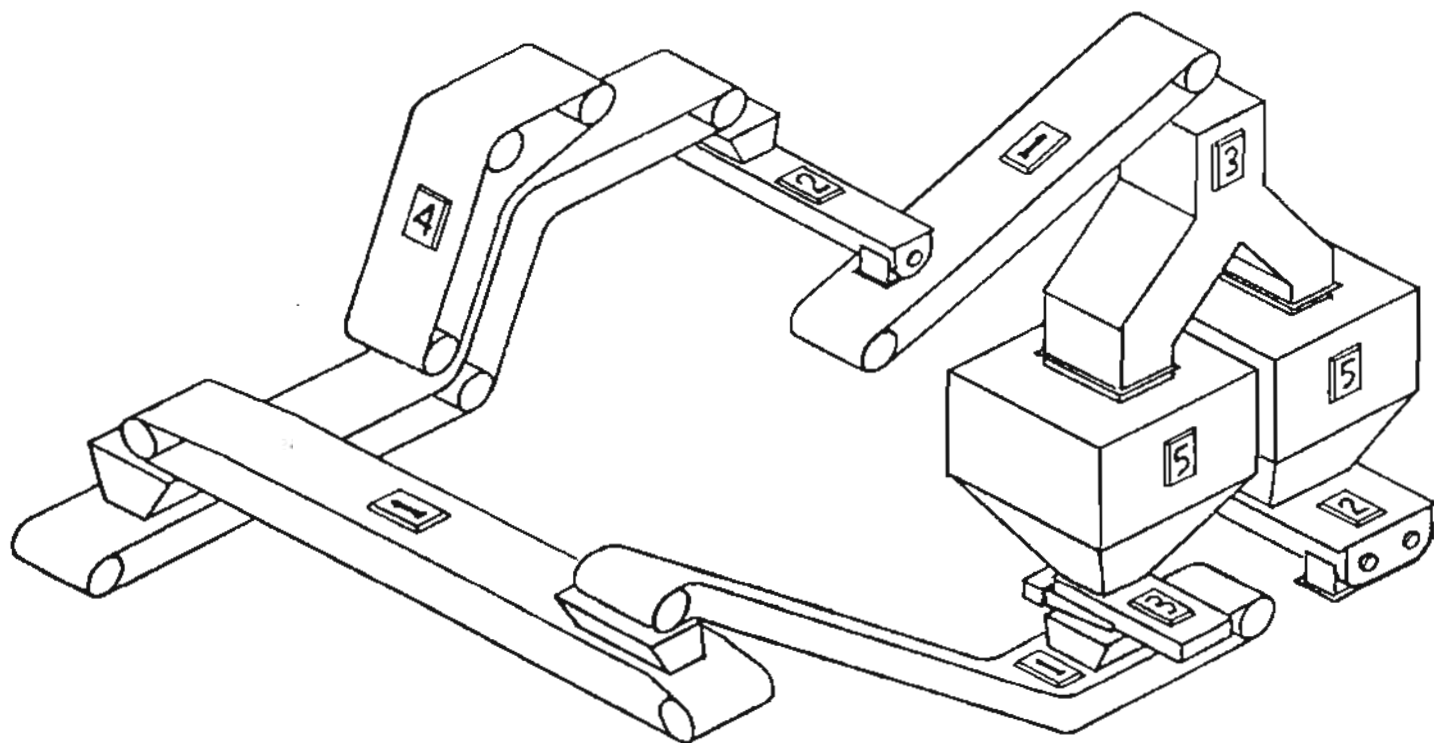

Specialists in Conveyor Systems